



MM[®] VSS Series Expansion Joint

Vertical Seismic Sealing System

SPECIAL DATA
 MM Systems Corp. • 50 MM Way, Pendergrass, GA 30567 • 800.241.3460 • www.mmsystems.com

DESCRIPTION

The Vertical Seismic Sealing System is a high performance expansion joint sealing system for vertical applications. A continuous elastoprene seal is snap locked into two aluminum frames securing it directly to the vertical opening. A secondary moisture barrier provides additional protection against water penetration.

BASIC USE

VSS is a watertight seismic sealing system designed for sealing vertical expansion joint openings in parking structures, buildings and other structures exposed to extreme weather conditions.

FEATURES

- Continuous locking Elastoprene[®] seal snaps into two aluminum frames.
- No visible aluminum or hardware.
- Engineered for multi-directional seismic movement.
- Resistant to UV, ozone, acid rain, most chemicals and extreme temperatures.
- Seal profile splices can be heat welded or chemically bonded with specialty adhesive.
- Factory fabricated tee's, crosses and directional changes are available.

SPECIAL FEATURES

- Compatible with most seismic expansion joints.
- Multiple seal seismic system available with pantograph centering device.
- Fire Barriers - MM expansion joint systems are available with appropriate 1 - 3 hour fire ratings.

LIMITATIONS

- Expansion joint openings must be parallel and straight to achieve watertight seal.

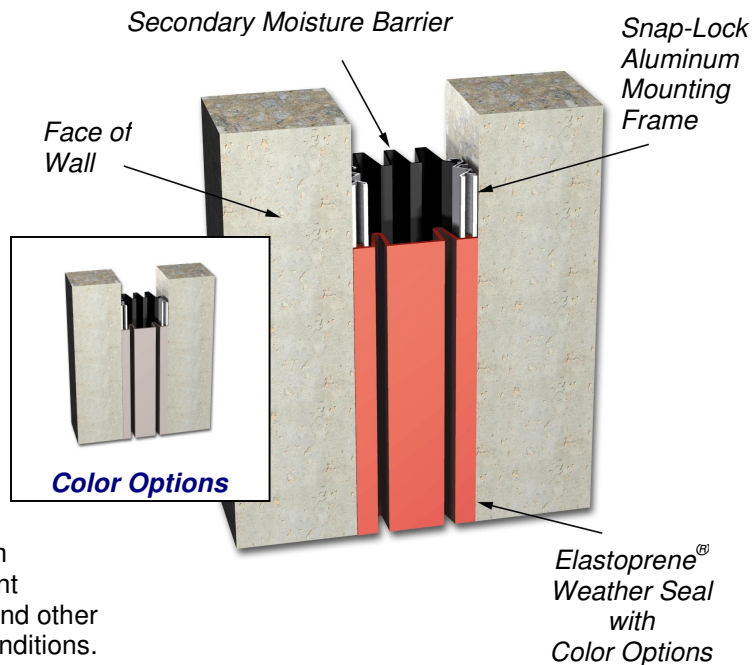

PACKAGING

Aluminum extrusion supplied in 10-foot lengths shipped on wooden pallets or cardboard cartons.

Hardware and other accessories packaged in cardboard cartons.

VSS Seals are supplied in longest possible lengths shipped on pallets, spools or cartons.

STORAGE

All materials should be stored in a cool, dry location 60-80°F (15-27°C) prior to use.

COLOR OPTIONS

Available in black, gray, beige and custom color match options.



MM[®] VSS Series Expansion Joint System

SELECTION GUIDE

Model Number	Total Movement		Joint Opening "A"					Installation Midpoint "A"		
			Min.	Max.	Seismic					
VSS-200	1.75	44	1.25	32	3.00	76	10.0	250	2.00	51
VSS-300	3.25	83	1.25	32	4.50	114	10.0	250	3.00	76
VSS-400	4.25	108	1.75	44	6.00	152	10.0	250	4.00	102
VSS-500	5.75	146	1.75	44	7.50	191	17.0	432	5.00	127
VSS-600	7.25	184	1.75	44	9.00	229	17.0	432	6.00	152
VSS-700	8.00	203	4.00	102	12.0	305	18.0	457	7.00	178
VSS-800	8.00	203	4.00	102	12.0	305	18.0	457	8.00	203
VSS-900	11.00	279	4.00	102	15.0	381	24.0	610	9.00	229
VSS-1000	11.00	279	4.00	102	15.0	381	24.0	610	10.00	254

Dimensions are in **inches** (bold) and millimeters. Larger sizes available. Call for details.

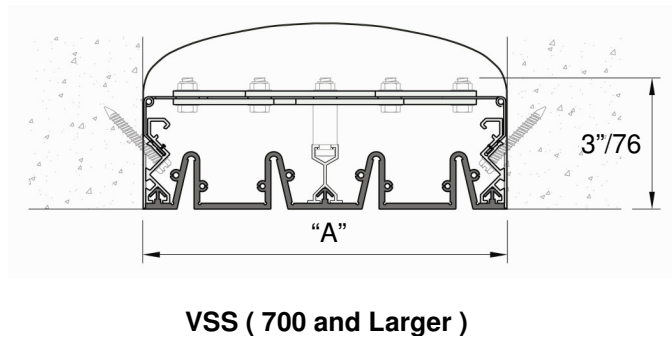
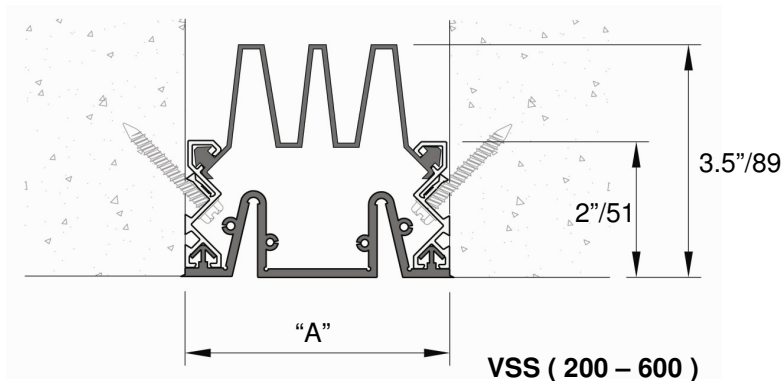

PHYSICAL PROPERTIES

Physical Property	Test Method	Value
Elastoprene-100		
Tensile Strength	ASTM D412	1000 psi
Ultimate Elongation	ASTM D412	445%
Hardness, Shore A	ASTM D2240	67 +/- 3
Tear Strength @ 73°F (23°C)	ASTM D624	140 pli / 24.5 kN/m
Tear Strength @ 212°F (100°C)	ASTM D624	58 pli / 10.2 kN/m
Compression Set @ 168 hours	ASTM D395	25% @ 23°C/ 73°F
Compression Set @ 168 hours	ASTM D395	38% @ 100°C/ 212°F
Ozone Resistance	ASTM D1149	No Cracks
UV Resistance	ASTM D695	Very Good
Brittle Point	ASTM D746	-76°F (-60°C)

NOTE: The foregoing information is published as general information only. The listed properties and performance characteristics are approximate values while actual field results may vary.

MM Systems reserves the right to amend or withdraw information contained herein, without notice, and will not be liable for any inaccuracy or ambiguity of said information.

LIMITED WARRANTY

MM Systems warrants the MM Vertical Seismic Sealing System to be free of defects in material and conform to technical data listed. We make no warranty as to color or appearance. Since methods of application can affect performance and on site conditions are beyond our control, MM Systems makes no other warranty, expressed or implied, including warranties of MERCHANTABILITY AND FITNESS FOR A PARTICULAR PURPOSE. MM Systems sole obligation shall be, at its option, to replace, or to refund the purchase price of the quantity of system proved to be defective. In no event shall MM Systems be liable for any special, incidental, consequential, loss of profits or punitive damages. Other warranties may be available when installed by a MM Certified Contractor.

INSTALLATION

- 1) Remove and repair all unsound concrete in and around the joint opening. All spalls must be repaired with compatible patching material.
- 2) Uncoil seal and allow it to relax in the sun for as long as possible before installation.
- 3) Attach aluminum frame to inside walls of joint with anchors supplied.
- 4) Directional Changes – insert galvanized splice pins (finishing nails) to align and reinforce splice connections before applying adhesive.
- 5) Insert the secondary moisture seal into aluminum frame first, then insert the weather seal and snap-lock into cavity.
- 6) Install in accordance with detailed installation guide.

Current Issue 02-08-11



50 MM Way, Pendergrass, GA 30567 • 800.241.3460 • www.mmsystemscorp.com

Spec Data