



# MM <sup>®</sup> SSP-EHD Series Expansion Joint

## Seismic Slide Plate Extra Heavy Duty System

SPECC DATA  
 MM Systems Corporation • 50 MM Way, Pendergrass, GA 30567 • 866.506.6929 • www.mm-usa.com

### DESCRIPTION

The SSP-EHD Extra Heavy Duty Series is designed for wide expansion joint openings with the ability to accommodate heavy loading and multi-directional seismic movement. Recessed extension plates allow the seismic slide plate to remain flush with finished deck surface. A seismic centering device with impact dampers and displacement springs allow the slide plate to displace and return to its natural position after a seismic occurrence. The integral impact and sound damper also acts as a waterstop. The rubber moisture barrier in conjunction LokCrete Elastomeric Concrete enhances the system's waterproofing capability.

### BASIC USE

SSP-EHD is a traffic bearing expansion joint for parking structures (convention centers, concourse areas, etc.) and other open-air structures requiring seismic movement capability. Contact MM for SNB Series "no-bump" interior design, SSS Series stainless steel cover design and STS surface mounted cover design.

### FEATURES

- For wide joints with multi-directional seismic movement.
- AASHTO HS-20 load carrying capability.
- Heavy-duty aluminum base members with interlocking frame design insures proper alignment.
- Fabric reinforced rubber gutter provides added moisture protection.
- Recessed extension plates allow for a smooth slab-to-slab transition.
- Complies with ADA guidelines.

### SPECIAL FEATURES

- Slide Plate and Base Frame with impact/sound dampener and waterstop.
- Solid aluminum seismic centering device with dynamic load impact damper. (Not plastic)
- LokCrete<sup>®</sup> - hard, elastic, abrasion resistant embed material that flexes with deck loads.
- Fire Barriers - MM expansion joint systems are available with 2 - 4 hour fire protection ratings.

### STORAGE

- LokCrete should be stored in a cool, dry location 60-80°F (15-27°C).

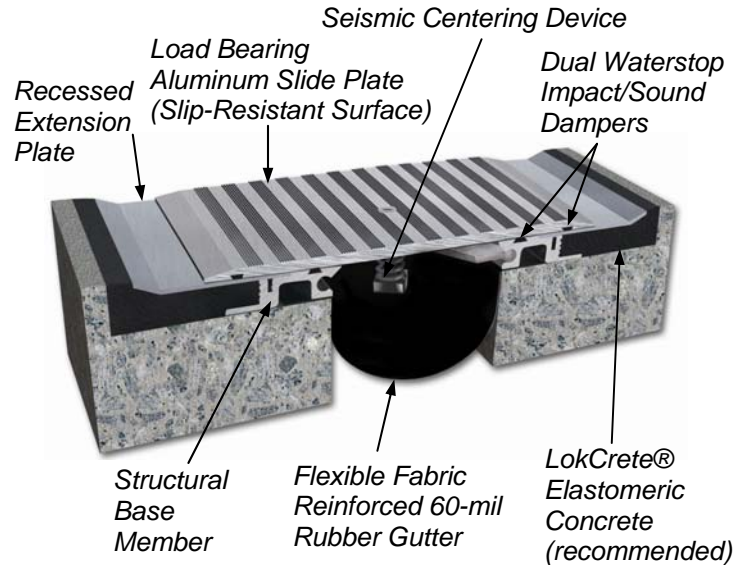

### SEISMIC CENTERING DEVICE

Structural bar, solid aluminum ball ends, impact dampener and adjustable single or dual tension springs.

### PACKAGING

Aluminum extrusion in 10-foot lengths shipped on wooden pallets. LokCrete is supplied in pre-measured Part A, B and C components. Accessories packaged in cardboard cartons.

### PRECAUTIONS

LokCrete - Use splash goggles and chemical resistant gloves to avoid prolonged or repeated skin contact. Use with adequate ventilation. In case of eye contact, immediately flush (low pressure) with lukewarm water. In case of skin contact, immediately wash skin with soap and water. Read and follow labels and Material Safety Data Sheet before use.

### LIMITATIONS

- Concrete blockouts must be properly formed, finished and have sound substrate.
- Joints located in turning lanes or exposed to forklift traffic must be engineered for greater impact loads – contact MM Systems.

# MM<sup>®</sup> SSP-EHD Series Expansion Joint

## SELECTION GUIDE

| Model Number | Total Movement |     | Joint Opening "A" |    |         |     |              |     | Slide Plate "B" |     | Blockout "C" |     | Blockout Depth "D" |    |
|--------------|----------------|-----|-------------------|----|---------|-----|--------------|-----|-----------------|-----|--------------|-----|--------------------|----|
|              |                |     | Seismic Min.      |    | Nominal |     | Seismic Max. |     |                 |     |              |     |                    |    |
| SSP-1000     | <b>14.0</b>    | 356 | <b>1.0</b>        | 25 | 10      | 254 | <b>15.0</b>  | 381 | <b>17.0</b>     | 432 | <b>7.5</b>   | 191 | <b>1.875</b>       | 48 |
| SSP-1200     | <b>17.0</b>    | 432 | <b>1.0</b>        | 25 | 12      | 305 | <b>18.0</b>  | 457 | <b>20.0</b>     | 508 | <b>8.5</b>   | 216 | <b>2.00</b>        | 50 |
| SSP-C-1000   | <b>10.75</b>   | 273 | <b>1.75</b>       | 44 | 10      | 254 | <b>12.5</b>  | 318 | <b>13.5</b>     | 343 | <b>7.5</b>   | 191 | <b>1.875</b>       | 48 |
| SSP-C-1200   | <b>13.25</b>   | 337 | <b>1.75</b>       | 44 | 12      | 305 | <b>15.0</b>  | 381 | <b>15.5</b>     | 394 | <b>8.5</b>   | 216 | <b>2.00</b>        | 50 |

Dimensions are shown in **inches** (bold) and millimeters. Contact MM Systems for larger sizes.

SSP-1000EHD utilizes a 3/8" slide plate cover while the SSP-1200EHD requires a 1/2" slide plate cover.

See SSP Series Spec Data Sheet for SSP-200 through SSP-800 Series.

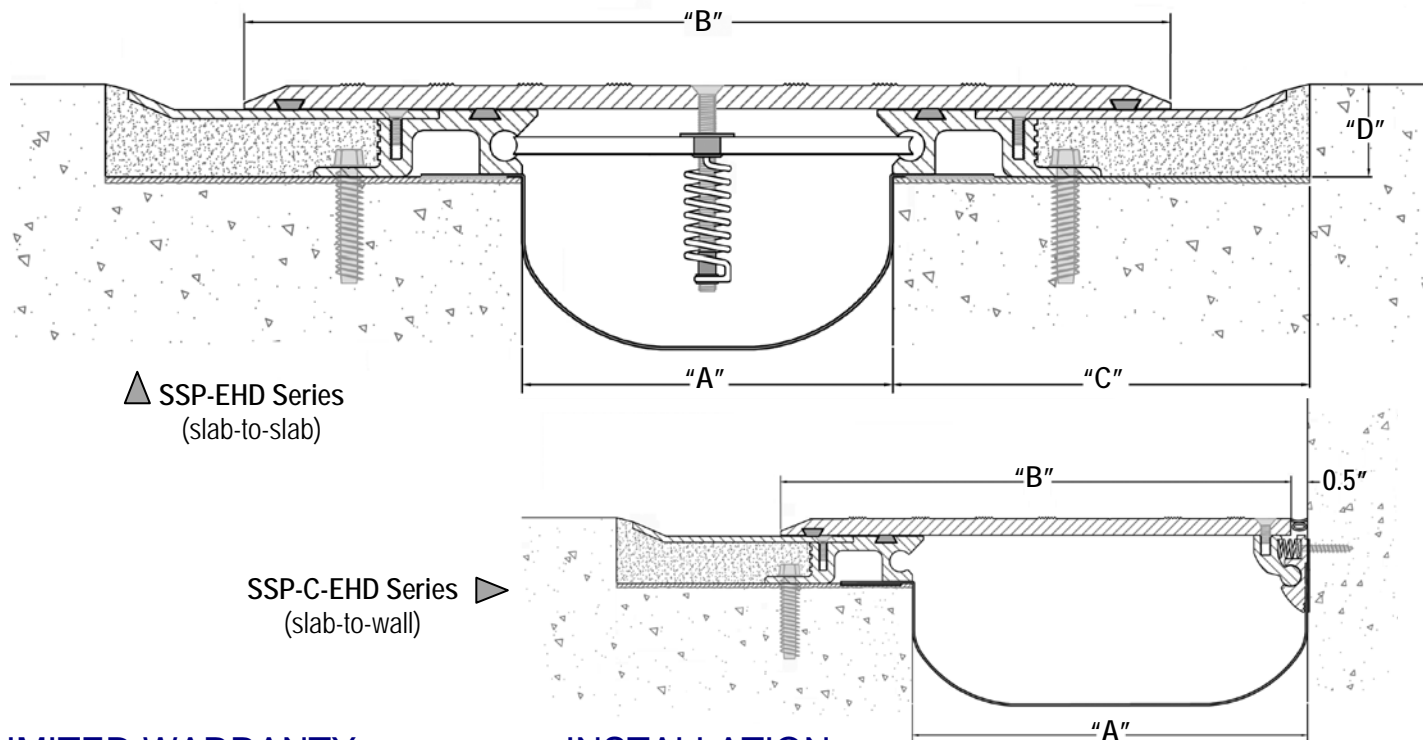

## LIMITED WARRANTY

MM Systems warrants the MM Seismic Extra Heavy Duty Slide Plate System to be free of defects in material and conform to technical data listed. We make no warranty as to color or appearance. Since methods of application can affect performance and on site conditions are beyond our control, MM Systems makes no other warranty, expressed or implied, including warranties of MERCHANTABILITY AND FITNESS FOR A PARTICULAR PURPOSE. MM Systems sole obligation shall be, at its option, to replace, or to refund the purchase price of the quantity of system proved to be defective. In no event shall MM Systems be liable for any special, incidental, consequential, loss of profits or punitive damages. Other warranties may be available when installed by a MM Certified Contractor.

## INSTALLATION

- 1) Remove and repair all unsound concrete in and around the blockout. All spalls must be repaired with compatible patching material.
- 2) Prepare substrate by sandblasting. The blockout must be clean and dry prior to installation of LokCrete Elastomeric Concrete (blockout filler).
- 3) Install base member with wedge bolt anchor.
- 4) Backfill blockout with infill material (LokCrete recommended) up to the height of the concrete blockout.
- 5) Immediately attach extension plates (remove duct tape).
- 6) Install seismic centering devices and slide plate with impact dampener.
- 7) Torque hardware per the SSP-EHD Installation Guideline.
- 8) Refer to the SSP-EHD Installation Guideline for detailed step-by-step instructions.

MM Systems reserves the right to amend or withdraw information contained herein, without notice, and will not be liable for any inaccuracy or ambiguity of said information.

Current Issue 4-11-11



Spec Data

50 MM Way, Pendergrass, GA 30567 • 866.506.6929 • www.mm-usa.com