



# MM<sup>®</sup> CIS Expansion Joint

## Cast-In Seismic System for Post-tension Decks

SPECC DATA  
 MM Systems Corp. • 50 MM Way, Pendergrass, GA 30567 • 866.506.6929 • www.mmsystems.com

### DESCRIPTION

The CIS Series is designed for wide expansion joint openings with the ability to accommodate heavy loading and multi-directional seismic movement. The cast-in design eliminates the need for blockouts and the adjustable hook bolts avoid interference with post-tension cables. The recessed design allows the seismic slide plate to remain flush with finished deck surface. A seismic centering device with dynamic load impact dampers and displacement springs allow the slide plate to displace and return to its natural position after a seismic occurrence. The high-density rubber impact and sound dampers also act as a waterstop. The integral flexible fabric reinforced rubber gutter enhances the system's waterproofing capability.

### BASIC USE

CIS is a traffic bearing expansion joint for parking structures with post tensioned concrete decks and other open-air structures requiring seismic movement and heavy duty low profile loading bearing designs.

### FEATURES

- For wide joints with multi-directional seismic movement.
- AASHTO HS-20 load carrying capability.
- Heavy-duty aluminum frames with interlocking design insures proper alignment.
- High strength hook bolts adjust around post tension cables.
- Slide plate cover available in stainless steel and aluminum.
- Recessed extension plates allow for a smooth slab-to-slab transition.
- Complies with ADA guidelines.

### SPECIAL FEATURES

- Cast-In design eliminates the need for blockouts and associated structural repairs.
- Slide Plate incorporates high-density rubber impact/sound dampener and waterstop.
- Solid aluminum seismic centering device with dynamic load impact damper. (Zero plastic)
- Fabric reinforced 60-mil rubber waterproofing gutter.
- Fire Barriers - MM expansion joint systems are available with 2 - 4 hour fire protection ratings.

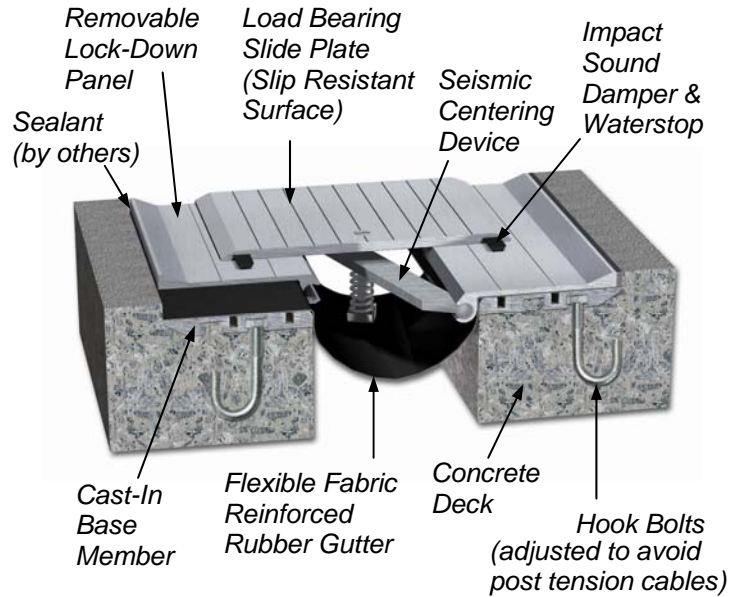

### SEISMIC CENTERING DEVICE

Structural centering bar, solid aluminum ball ends, impact damper and adjustable single or dual tension springs.

### PACKAGING

Slide plates and lock-down panels supplied in 10' lengths and cast-in-place base frame in 20' lengths shipped on wooden pallets. Accessories packaged in cardboard cartons.

### STORAGE / PRECAUTIONS

Store in a dry location prior to use. Read and follow labels and Material Safety Data Sheet before use.

### LIMITATIONS

- Concrete must be properly consolidated beneath and around the expansion joint system.
- Joints located in turning lanes or exposed to forklift traffic must be engineered for greater impact loads – contact MM Systems.

# MM<sup>®</sup> CIS Series Expansion Joint

## SELECTION GUIDE

Model Number	Total Movement		Joint Opening "A"						Slide Plate "B"		Cast-In Base "C"	
			Min.		Nominal		Max.					
CIS-400	<b>3.50</b>	89	<b>2.5</b>	64	4	102	<b>6.0</b>	152	<b>8.0</b>	203	<b>5.25</b>	133
CIS-600	<b>6.50</b>	165	<b>2.5</b>	64	6	152	<b>9.0</b>	229	<b>11.0</b>	279	<b>5.25</b>	133
CIS-800	<b>9.50</b>	241	<b>2.5</b>	64	8	203	<b>12.0</b>	305	<b>14.0</b>	356	<b>7.25</b>	184
CIS-1000	<b>12.5</b>	318	<b>2.5</b>	64	10	254	<b>15.0</b>	381	<b>17.0</b>	432	<b>7.25</b>	184
CIS-1200	<b>15.5</b>	394	<b>2.5</b>	64	12	305	<b>15.0</b>	381	<b>20.0</b>	508	<b>7.25</b>	184
CIS-C-400	<b>2.50</b>	64	<b>2.5</b>	64	4	102	<b>5.0</b>	127	<b>5.5</b>	140	<b>5.25</b>	133
CIS-C-600	<b>5.00</b>	127	<b>2.5</b>	64	6	152	<b>7.5</b>	191	<b>8.0</b>	203	<b>5.25</b>	133
CIS-C-800	<b>7.50</b>	191	<b>2.5</b>	64	8	203	<b>10.0</b>	254	<b>10.5</b>	267	<b>7.25</b>	184
CIS-C-1000	<b>10.0</b>	254	<b>2.5</b>	64	10	254	<b>12.5</b>	318	<b>13.0</b>	330	<b>7.25</b>	184
CIS-C-1200	<b>12.5</b>	318	<b>2.5</b>	64	12	254	<b>15.0</b>	381	<b>15.5</b>	395	<b>7.25</b>	184

Dimensions are shown in **inches** (bold) and millimeters. Contact MM Systems for larger sizes.

Note: CIS-1200 requires a 1/2" thick load bearing slide plate cover. All other covers are 3/8" thick.

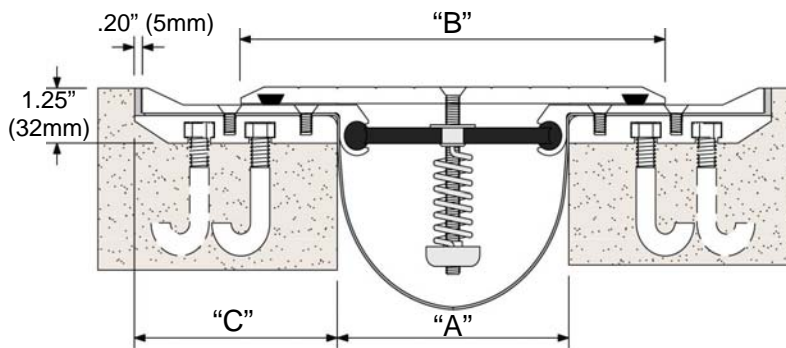

**CIS Series** (Slab-to-Slab)

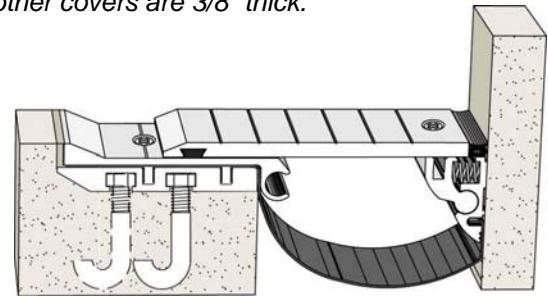

**CIS-C Series** (Slab-to-Wall)

## LIMITED WARRANTY

MM Systems warrants the Cast-In Seismic System to be free of defects in material and conform to technical data listed. We make no warranty as to color or appearance. Since methods of application can affect performance and on site conditions are beyond our control, MM Systems makes no other warranty, expressed or implied, including warranties of MERCHANTABILITY AND FITNESS FOR A PARTICULAR PURPOSE. MM Systems sole obligation shall be, at its option, to replace, or to refund the purchase price of the quantity of system proved to be defective. In no event shall MM Systems be liable for any special, incidental, consequential, loss of profits or punitive damages.

Other warranties may be available when installed by a MM Certified Contractor.

## INSTALLATION

- 1) Attach cast-in aluminum embed frame to expansion joint opening formwork.
- 2) Insure that the joint opening width has been adjusted based on temperature at time of concrete placement. Consult with engineer of record for adjustment table.
- 3) Vibrate concrete formwork to insure proper concrete consolidation beneath the aluminum cast-in base frame.
- 4) Remove the plywood formwork that adjoins the two cast-in embed frames.
- 5) Install the 60-mil fabric reinforced rubber gutter.
- 6) Install the lock-down panels. Stagger the panels to interlock the system.
- 7) Install seismic centering devices and slide plate with impact dampener.
- 8) Install seismic slide plate along with splice connectors and slip connectors.
- 9) Torque hardware per CIS Installation Guideline.
- 10) Refer to CIS Installation Guideline for detailed step-by-step instructions.

MM Systems reserves the right to amend or withdraw information contained herein, without notice, and will not be liable for any inaccuracy or ambiguity of said information.

Current Issue 2-26-09



Spec Data