

**STEP 1** - Square off the seal ends to be joined when adjoining the ends of two lengths of seal together. Clean rubber seal ends with Denatured Alcohol and let dry.

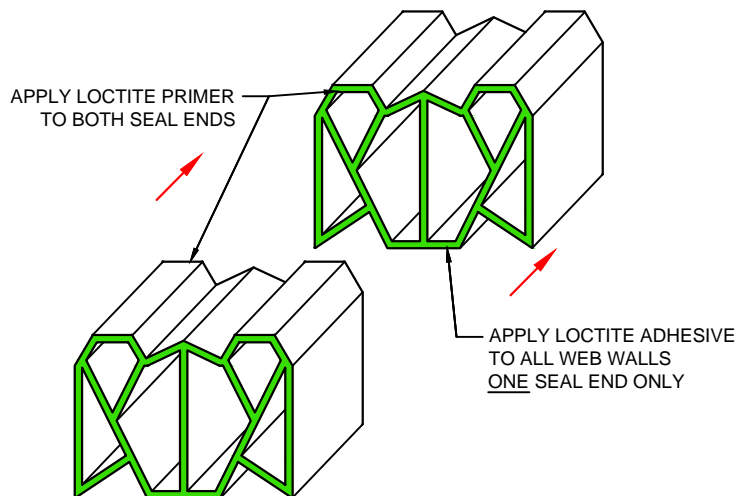

**STEP 2** - Adjoin ends of seal together by applying **Loctite Primer** to both ends and **Loctite Adhesive** to only one of the ends to be joined. Hold ends together for approximately 15 seconds.

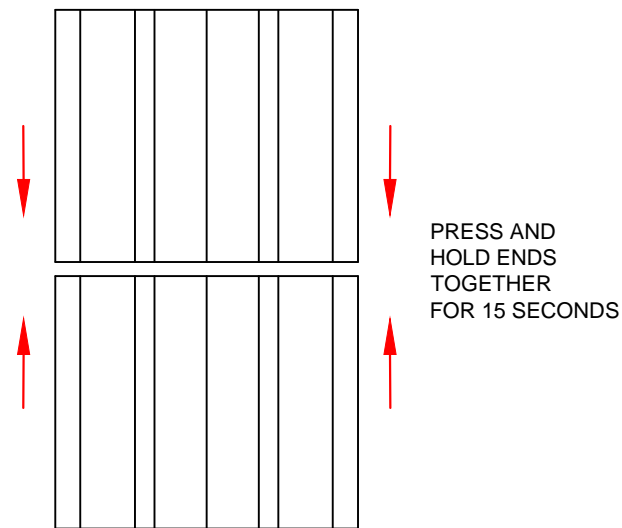

**STEP 3** - Cut 6" wide uncured EPDM rubber sheet into 2" wide strips. Remove protective liner from 2" splice strip immediately prior to adhering to back side of rubber seal. (No Cleaning Required).

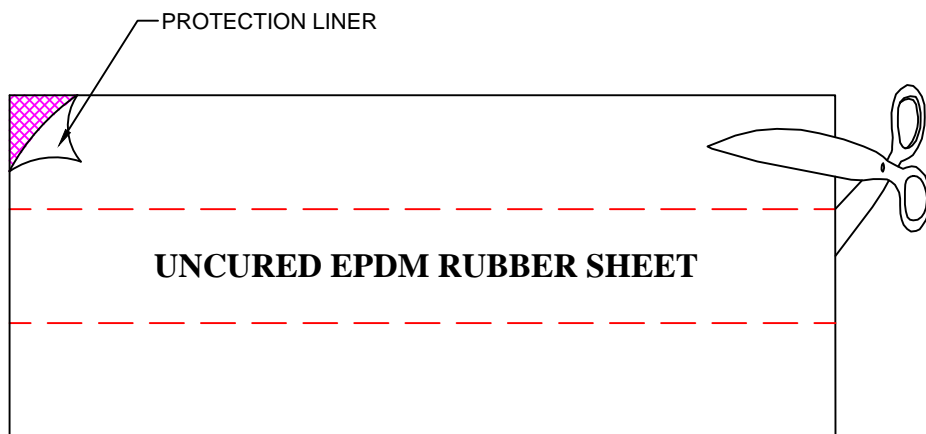

**STEP 4** - Apply **Loctite Primer** to the entire seal & splice strip contact area. Apply **Loctite Adhesive** only to the seal surface one inch at a time. Use margin trowel to hold the splice strip in place for 15 seconds. Continue on inch at a time until the entire strip is bonded to the seal.

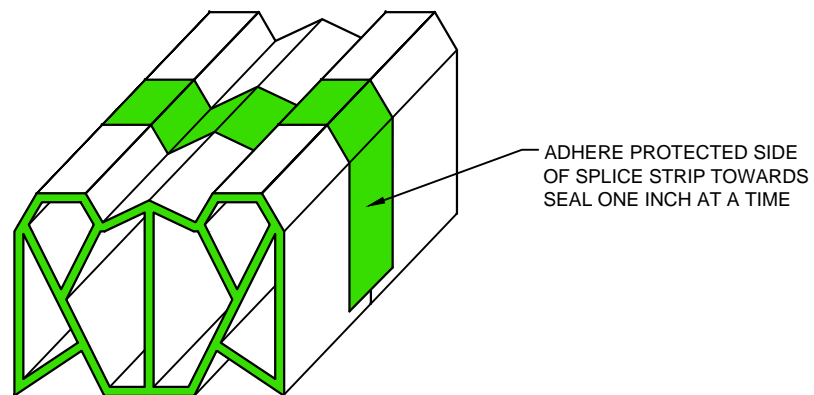

**MM**  
MM SYSTEMS

50 MM WAY  
PENDERGRASS, GA. 30567  
PHONE: 706-824-7500  
866-506-6929  
FAX: 706-824-7501

[www.mm-usa.com](http://www.mm-usa.com)

For Spec-Data, Installation Guides, or movement requirements, contact MMSC

**RIGHTS OF DESIGN**

All rights of design, detail, engineering and/or invention contained herein are the property of MM Systems Corporation and hereby reserved and are not to be reproduced or provided to any other party. MM Systems Corporation reserves the right to amend or withdraw any information contained herein without notice and will not be liable for any inaccuracy or ambiguity of said information.

**Vertical Compression Seal**

**VCS Field Butt Splice Transition**

Drawn by: DMW	Scale: NTS	Drawing Number: <b>31401-01</b>
SHT. 1 OF 1	Issue Date: 01-11-2012	