

IMPORTANT LIFE SAFETY PRODUCT NOTE

To achieve 2 hour rating the Pyro-Flex Fire Barriers must be installed in a 2-hour rated concrete slab, minimum 4.5-inch thickness joint face in accordance with IBC Table 721.2.2.1 "Minimum Slab Thickness". Prior to order placement contact MM Systems to validate fire barrier size compatibility with proposed concrete slab thickness. Adjustments may be necessary to meet fire rated code compliance based on both minimum and maximum expansion joint opening. Fire barriers must be installed in strict accordance with project specific MM Systems Fire Barrier Installation Instructions.

LISTED AND LABELED WITH INTERTEK LABORATORIES

DIH-C-600-1.0 Fire Rated Expansion Joint
(Floor-to-Wall / 1" Corner)



MM
MM SYSTEMS

50 MM WAY
PENDERGRASS, GA. 30567
PHONE: 706-824-7500
866-506-6929
FAX: 706-824-7501

www.mm-usa.com

For Spec-Data, Installation Guides, or movement requirements, contact MMSC

RIGHTS OF DESIGN

All rights of design, detail, engineering and/or invention contained herein are the property of MM Systems Corporation and hereby reserved and are not to be reproduced or provided to any other party. MM Systems Corporation reserves the right to amend or withdraw any information contained herein without notice and will not be liable for any inaccuracy or ambiguity of said information.

Dual Interlocking Hinge Expansion Joint

DIH-C-600-1.0 Series & Pyro-Flex Fire Barrier

Drawn by: DMW	Scale: NTS	Drawing Number: 30953-10
Sheet 1 of 2	Issue Date: 01-29-2019	

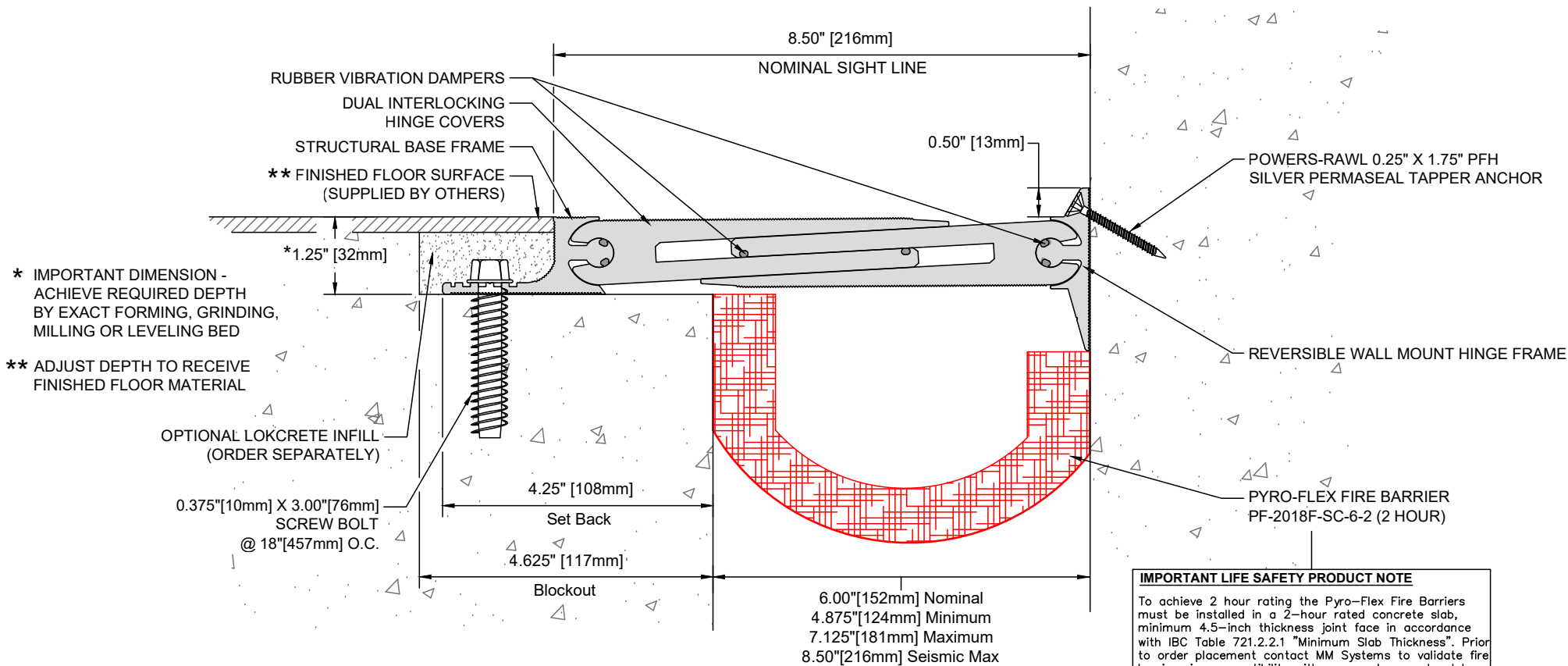

DIH-C-600-0.5 Fire Rated Expansion Joint
(Floor-to-Wall / 0.50" Corner)

IMPORTANT LIFE SAFETY PRODUCT NOTE

To achieve 2 hour rating the Pyro-Flex Fire Barriers must be installed in a 2-hour rated concrete slab, minimum 4.5-inch thickness joint face in accordance with IBC Table 721.2.2.1 "Minimum Slab Thickness". Prior to order placement contact MM Systems to validate fire barrier size compatibility with proposed concrete slab thickness. Adjustments may be necessary to meet fire rated code compliance based on both minimum and maximum expansion joint opening. Fire barriers must be installed in strict accordance with project specific MM Systems Fire Barrier Installation Instructions.

LISTED AND LABELED WITH INTERTEK LABORATORIES



MM
MM SYSTEMS

50 MM WAY
PENDERGRASS, GA. 30567
PHONE: 706-824-7500
866-506-6929
FAX: 706-824-7501

www.mm-usa.com

For Spec-Data, Installation Guides, or movement requirements, contact MMSC

RIGHTS OF DESIGN

All rights of design, detail, engineering and/or invention contained herein are the property of MM Systems Corporation and hereby reserved and are not to be reproduced or provided to any other party. MM Systems Corporation reserves the right to amend or withdraw any information contained herein without notice and will not be liable for any inaccuracy or ambiguity of said information.

Dual Interlocking Hinge Expansion Joint

DIH-C-600-0.5 Series & Pyro-Flex Fire Barrier

Drawn by:
DMW

Scale:
NTS

Drawing Number:

Sheet 2 of 2

Issue Date:
01-29-2019

30953-10