

IMPORTANT LIFE SAFETY NOTE
 4-1/2" MINIMUM FACE OF SLAB (AS SHOWN) REQUIRED FOR OPTIONAL FIRE RATING TO BE AVAILABLE IN ACCORDANCE TO IBC TABLE 721.2.2.1 "MINIMUM SLAB THICKNESS" ARCHITECT / CONTRACTOR MUST VERIFY PRIOR TO FABRICATION.

IMPORTANT LIFE SAFETY PRODUCT NOTE
 PF-2018F-SC-2-1 (OPTIONAL)
 TO ACHIEVE RATING, 2-HOUR FIRE BARRIER MUST BE INSTALLED IN 2-HOUR RATED SLAB, MINIMUM 4-1/2" JT. FACE. BARRIERS MUST BE INSTALLED IN STRICT ACCORDANCE WITH TYPICAL FLOOR FIRE BARRIER INSTALLATION INSTRUCTIONS PROVIDED IN THIS SUBMITTAL.

* CONTACT FACTORY FOR OTHER STYLES OF FIRE BARRIER

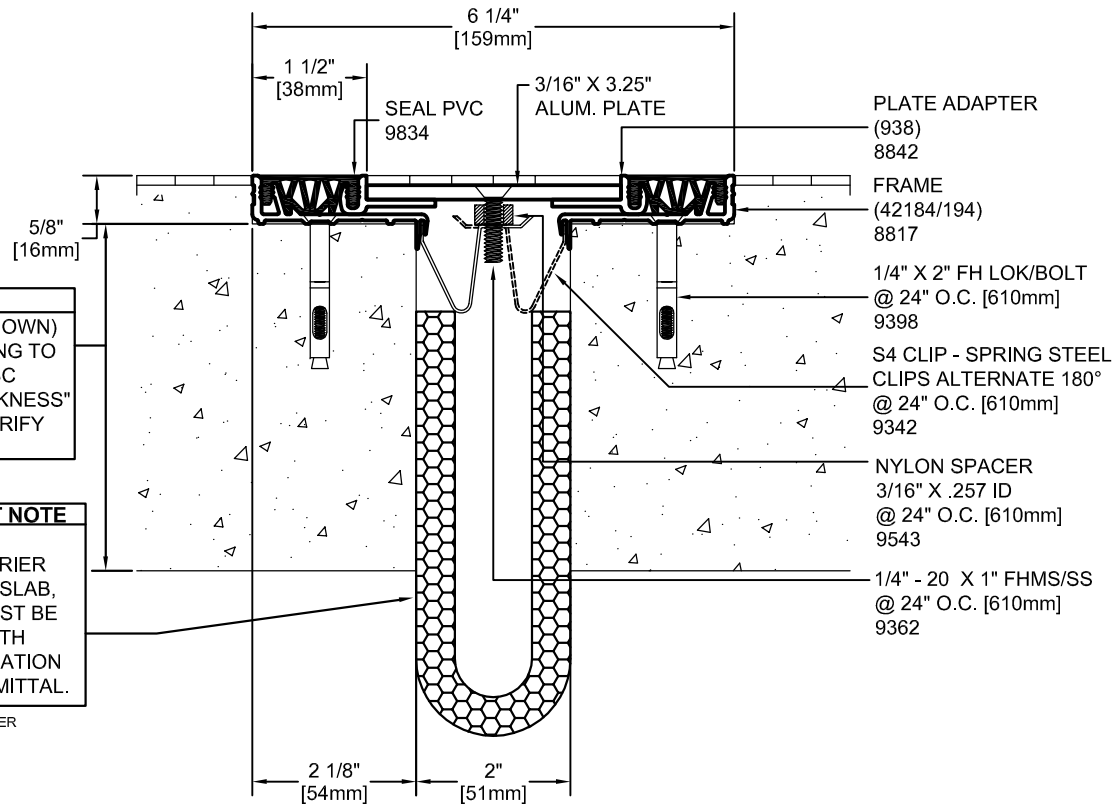

Model	Nominal "JT"	Joint Opening "JT"				Total Movement	Mat. Code
		Seismic Min.	Thermal Min.	Thermal Max.	Seismic Max.		
FDT-200-.125R	2"	1"	1.8125"	2.1875"	3.25"	2.25"	FD1306
FDT-200-.125R w/ PF-2018F-SC-2-1	2"	1"	1.8125"	2.1875"	3"	2"	FD1306

* NOTE THAT SEALS DISENGAGE FROM FRAME AFTER THERMAL MIN AND THERMAL MAX.

ARCHITECT/CONTRACTOR NOTE:
 ALL SUBASSEMBLY COMPONENTS TO BE PROVIDED IN 10'-0" OR 20'-0" STOCK LENGTHS UNLESS OTHERWISE NOTED. THE SPECIFIC SYSTEMS DICTATE THE LENGTHS PROVIDED.

Approved by: _____ Date: _____
SEAL NOTE: SPECIFY SEAL COLOR
 STANDARD COLORS:
 CARBON (BLACK) PRAIRIE (BEIGE)
 FOG (GRAY) LUNAR (WHITE)
*CUSTOM COLOR AVAILABLE IN MINIMUM QUANTITIES 100 LF. CONTACT MM FOR PRICING & AVAILABILITY.

Representative:	Customer:	Project:	Location:	Project Number:
-----------------	-----------	----------	-----------	-----------------



MM SYSTEMS
 50 MM WAY
 PENDERGRASS, GA. 30567
 PHONE: 706-824-7500
 800-241-3460
 FAX: 706-824-7501
www.mmsystemscorp.com

For Spec-Data, Installation Guides, or movement requirements, contact MMSC

RIGHTS OF DESIGN
 All rights of design, detail, engineering and/or invention contained herein are the property of MM Systems Corporation and hereby reserved and are not to be reproduced or provided to any other party. MM Systems Corporation reserves the right to amend or withdraw any information contained herein without notice and will not be liable for any inaccuracy or ambiguity of said information.

FDT-200-.125R

Model:	Scale:	Drawing Number:
Drawn by: LMP	NTS	FD1306
SHT. . OF .	Issue Date: 08-15-11	