

IMPORTANT LIFE SAFETY NOTE
 NOTE 2 BARRIERS REQUIRED.
 MINIMUM WALL DEPTH REQUIRED FOR RATING:
 6.75" FOR SINGLE SIDE INSTALLATION (SHOWN)
 ARCHITECT / CONTRACTOR MUST VERIFY PRIOR
 TO FABRICATION

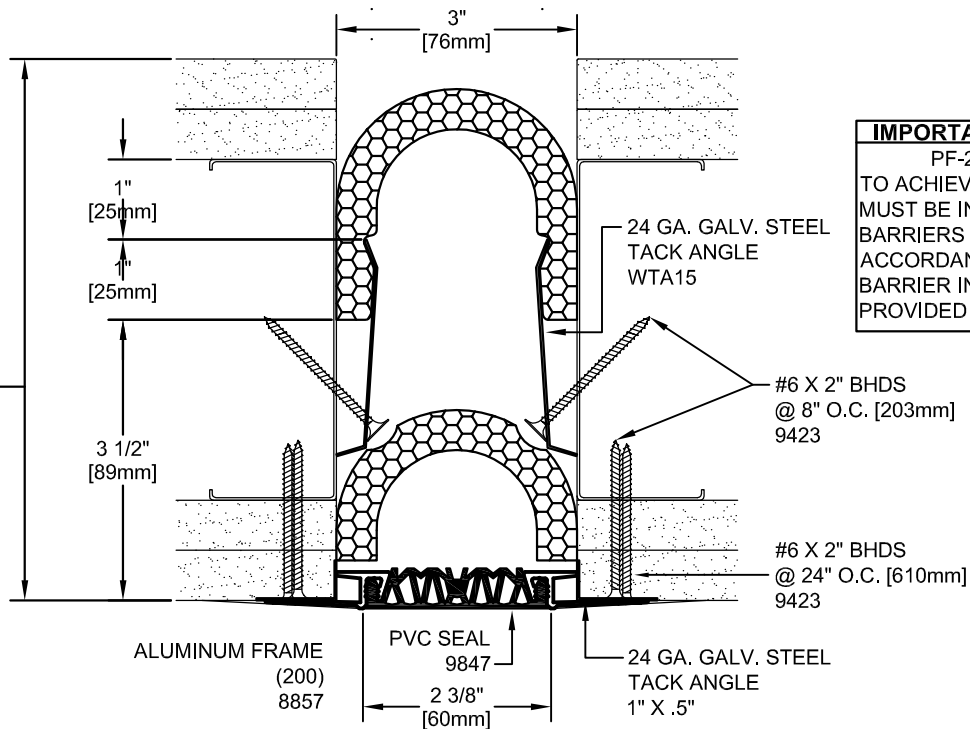

IMPORTANT LIFE SAFETY PRODUCT NOTE
 PF-2018CW-SC-3-1.5
 TO ACHIEVE RATING, 2-HOUR FIRE BARRIER
 MUST BE INSTALLED IN 2-HOUR RATED WALL.
 BARRIERS MUST BE INSTALLED IN STRICT
 ACCORDANCE WITH TYPICAL WALL FIRE
 BARRIER INSTALLATION INSTRUCTIONS
 PROVIDED IN THIS SUBMITTAL.

Model	Nominal "JT"	Joint Opening "JT"				Total Movement	Mat. Code
		Seismic Min.	Thermal Min.	Thermal Max.	Seismic Max.		
FSW-300_STUD_2HWPF_SS	3"	1.9375"	2.5"	3.5"	3.6875"	1.75"	

* NOTE THAT SEALS DISENGAGE FROM FRAME AFTER THERMAL MIN AND THERMAL MAX.

ARCHITECT/CONTRACTOR NOTE:
 ALL SUBASSEMBLY COMPONENTS TO BE
 PROVIDED IN 10'-0" OR 20'-0" STOCK LENGTHS
 UNLESS OTHERWISE NOTED. THE SPECIFIC
 SYSTEMS DICTATE THE LENGTHS PROVIDED.

Approved by: _____ Date: _____
SEAL NOTE: SPECIFY SEAL COLOR
 STANDARD COLORS:
 CARBON (BLACK) PRAIRIE (BEIGE)
 FOG (GRAY) LUNAR (WHITE)
*CUSTOM COLOR AVAILABLE IN MINIMUM QUANTITIES 100 LF.
 CONTACT MM FOR PRICING & AVAILABILITY.

Representative:	Customer:	Project:	Location:	Project Number:
-----------------	-----------	----------	-----------	-----------------

MM SYSTEMS
 50 MM WAY
 PENDERGRASS, GA. 30567
 PHONE: 706-824-7500
 800-241-3460
 FAX: 706-824-7501
www.mmsystemscorp.com
 For Spec-Data, Installation Guides, or movement requirements, contact MMSC

RIGHTS OF DESIGN
 All rights of design, detail, engineering and/or
 invention contained herein are the property of MM
 Systems Corporation and hereby reserved and are not
 to be reproduced or provided to any other party. MM
 Systems Corporation reserves the right to amend or
 withdraw any information contained herein without
 notice and will not be liable for any inaccuracy or
 ambiguity of said information.

FSW-300_STUD_2HWPF_SS
 Model:
 Drawn by: LMP Scale: NTS Drawing Number:
 SHT. . OF . Issue Date: 12-12-14